

A
B
C
D
E

A
B
C
D
E

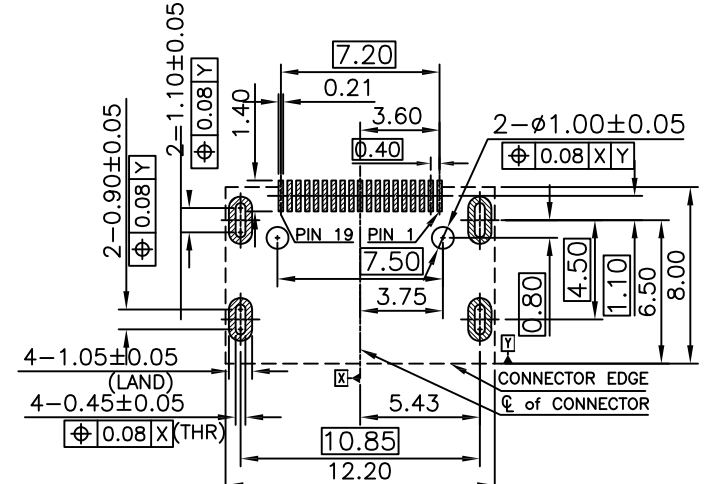
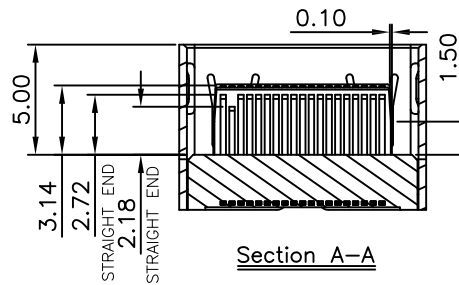
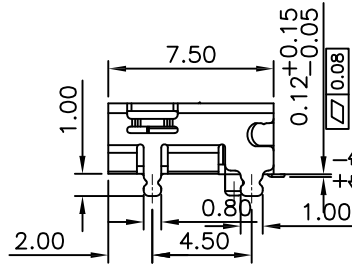
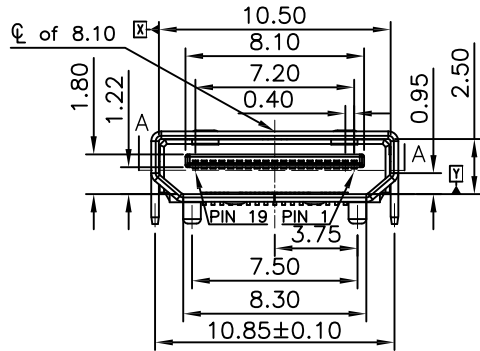
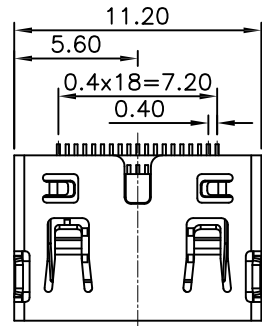

RECOMMENDED P.C.BOARD LAYOUT (TOP VIEW)
TOLERANCES UNLESS OTHERWISE SPEC.±0.05
▨ PAD AREA □ KEEP OUT AREA

TECHNICAL REQUIREMENTS:

1. MECHANICAL:
 - 1.1 WITHDRAWAL FORCE AFTER 2000 CYCLES: 39.2N MAX,9.8N Min.
 - 1.2 WITHDRAWAL FORCE AFTER 2001-10000 CYCLES:4.9N Min,39.2N Max.
 - 1.3 INSERTION FORCE:44.1N Max.
2. ELECTRICAL:
 - 2.1 CONTACT CURRENT RATING: 0.5A MIN.
 - 2.2 VOLTAGE RATING: 40V AC(RMS)
 - 2.3 WITHSTANDING VOLTAGE:
 - 500 VOLTS AC BETWEEN ADJACENT TERMINAL.(UNMATE)
 - 300 VOLTS AC BETWEEN ADJACENT TERMINAL.(MATE)
 - 2.4 INSULATION RESISTANCE:
 - 100 MOHM MIN.(UNMATED); 10 MOHM MIN.(MATED)
 - 2.5 CONTACT RESISTANCE: 30 MILLIOHMS MAX.
3. ENVIRONMENTAL:
 - 3.1 OPERATING TEMPERATURE: -25℃ to +85℃
 - 3.2 STORAGE TEMPERATURE: 20℃ TO 25℃

1	HOUSING	LCP BLACK UL94V-0	③
19	CONTACT	COPPER ALLOY, GOLD FLASH PLATED ON CONTACT AREA TIN PLATING ON SOLDER AREA, NI PLATING UNDER OVER ALL	②
1	SHELL	SPCC/BRASS ,NI PLATING OVER ALL.	①
QTY'S	PART	SPECIFICATION	ITEM

版本 千川	變更內容 MODIFIXATION	日期 DATE

 東莞市千川电子有限公司
DONG GUAN QIAN CHUAN ELECTRONIC CO., LTD

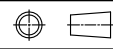
公差 TOLERANCE	數量 QUANTITY	制圖 DRAW IN	潘富国	品名 TITLE	MINI HDMI 19Pin 母座 卧式SMT 四脚插板 L=7.50mm	
.X ±0.35	單位 UNIT	審核 CHECKED	JX	料號 PART NO.	QHCF A1-GFBNOR40	
.XX ±0.25	比例 SCALE	核准 APPROVE	LGL	材質 MATERIAL		
.XXX±0.15	圖幅 SIZE	角法 PROJ.		頁數 SHEET	1 OF 2	顏色 COLOR
X° ± 3°						
.X° ± 1.5°						

F

F