

SPECIFICATIONS:

1. MECHANICAL :
  - 1.1 INSERTION FORCE : 44.1 N MAX
  - 1.2 WITHDRAWAL FORCE : 9.8 N MIN.
 AFTER 5,000 CYCLES MATING: 0.5kgf MIN.
2. ELECTRICAL :
  - 2.1 CONTACT CURRENT RATING: 0.5A MIN.
  - 2.2 VOLTAGE RATING : 40V AC (rms)
  - 2.3 WITHSTANDING VOLTAGE: 500 VAC FOR 1 MINUTE.
  - 2.4 INSULATION RESISTANCE: 100 MEGOHMS MIN
  - 2.5 CONTACT RESISTANCE: 30 MILLIOHMS MAX.
3. ENVIRONMENTAL :
  - 3.1 OPERATING TEMPERATURE: -25° C TO +85° C

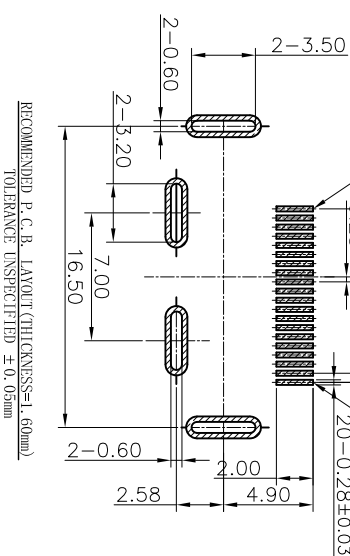
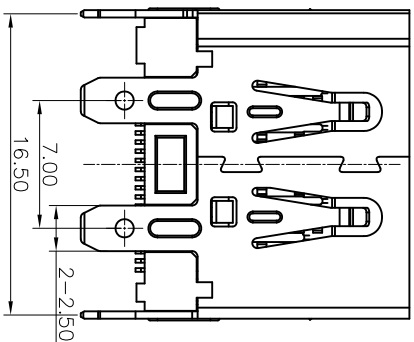
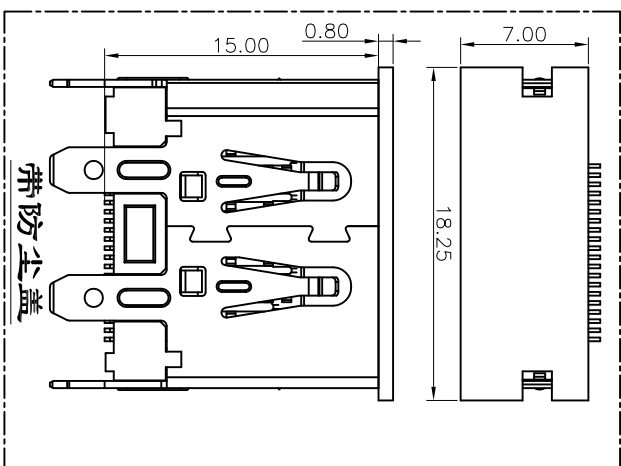
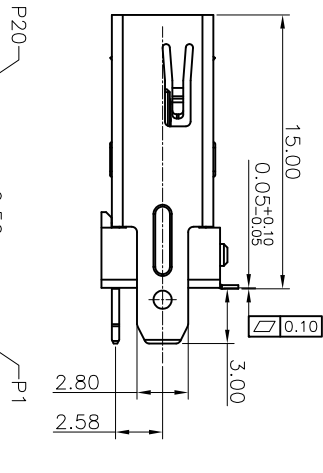
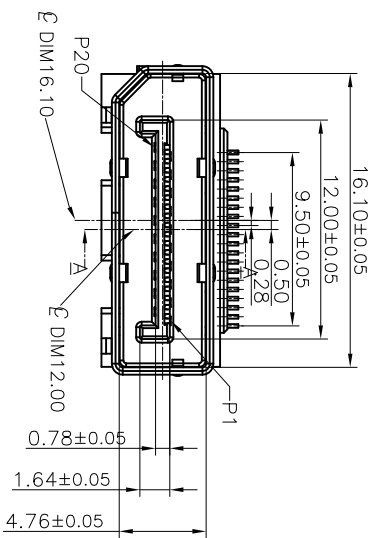

RECOMMENDED P.C.B. LAYOUT (THICKNESS: L: 60mm)  
TOLERANCE: UNSPECIFIED ± 0.05mm

ITEM	QTY'S	PART	制圖 DRAWING	數量 QUANTITY	單位 UNIT	公差 TOLERANCE	料號 PART NO.	品名 TITLE	SPECIFICATION
4	1	DUST COVER	Toms	1	mm	X ± 0.35	LJ	DP 20Pin 母座 立式SMT 无卷边 四脚插板 H=15.00	LCP BLACK UL94V-0
3	20	CONTACT	LJ	20	mm	XX ± 0.25	LJ		COPPER ALLOY; GOLD PLATED OVER NICKEL ON CONTACT AREA AND 100μ" MIN. TIN PLATED OVER NICKEL ON SOLDER TAILS
2	1	HOUSING	LGL	1	mm	.XXX ± 0.15	LGL		LCP BLACK UL94V-0
1	1	SHELL	LGL	1	mm	X° ± 3°	LGL		SPCC/COPPER ALLOY NICKEL PLATED

版本 REV	變更內容 MODIFICATION	日期 DATE
1		



東莞市千川电子有限公司  
DONG GUAN QIAN CHUAN ELECTRONIC CO., LTD

公差 TOLERANCE	數量 QUANTITY	單位 UNIT	料號 PART NO.	品名 TITLE	SPECIFICATION
X ± 0.35		mm	LJ	DP 20Pin 母座 立式SMT 无卷边 四脚插板 H=15.00	
XX ± 0.25		mm	LJ		
.XXX ± 0.15		mm	LGL		
X° ± 3°		度	LGL		
X° ± 15°		度	LGL		

圖 SIZE	角法 PROJ.	頁數 SHEET	1 OF 1	顏色 COLOR
4:4				